

Walking with Robots

My experience of sharing robotics

Sam Wane

s.o.wane@staffs.ac.uk

www.fcet.staffs.ac.uk/sow1

The Roadmap



- Teaching
 - Level 1,2 & 3
 - Masters
- Research
 - PhD
 - Conferences
- Public Engagement
 - STEM
 - Café Sci
- Competitions
- Web links

Me-Rehab Robotics & Food Industry



an LED control panel for easy selection



a heat tray

a cup (optional)

a purpose designed spoon

a sectioned food dish

an LED control panel for easy selection



mirrors

make-up holders

a selection of make-up applicators



a washing bowl

mirrors

**a sponge,
electric shaver,
electric toothbrush
and a rinsing cup**

Level 1

- Lego NXT robots
- Intro to C
 - Line follow
 - Kinematics
 - Decide at junctions
- Path planning



Level 1-Hardware/Software

- Use NXC

```
task main()
{
    OnFwd(OUT_B, 50);
    OnFwd(OUT_C, 60);
    Wait(1000);
    Off(OUT_B);
    Off(OUT_C);
}
```



Level 1-Line follow

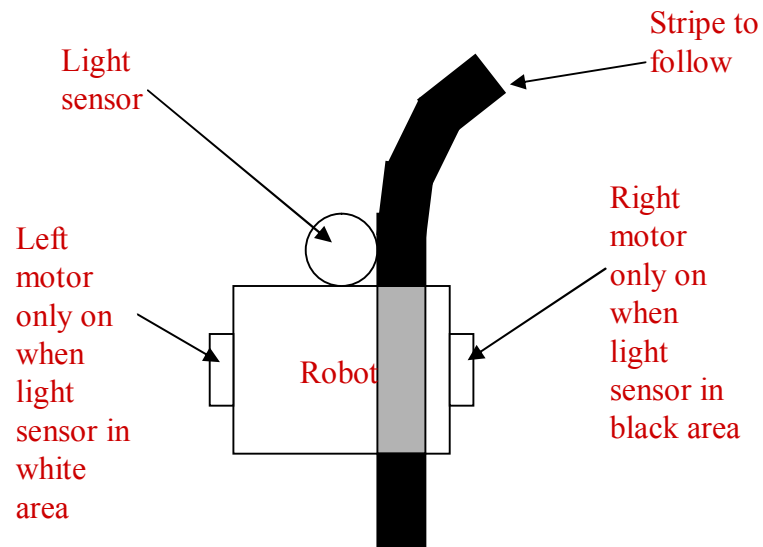

Level 1-Content

- Using encoders

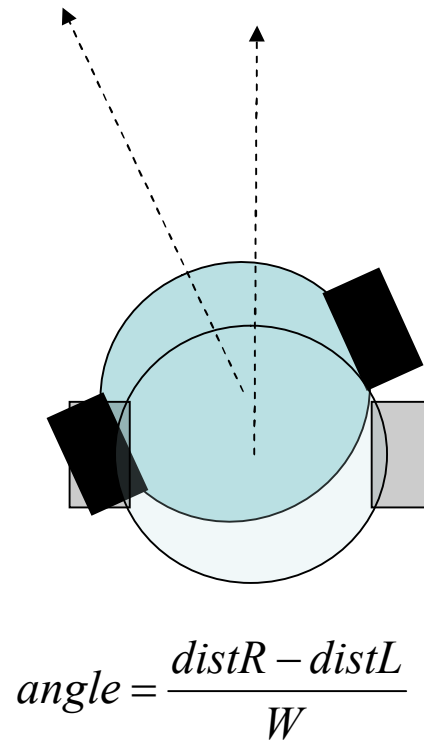
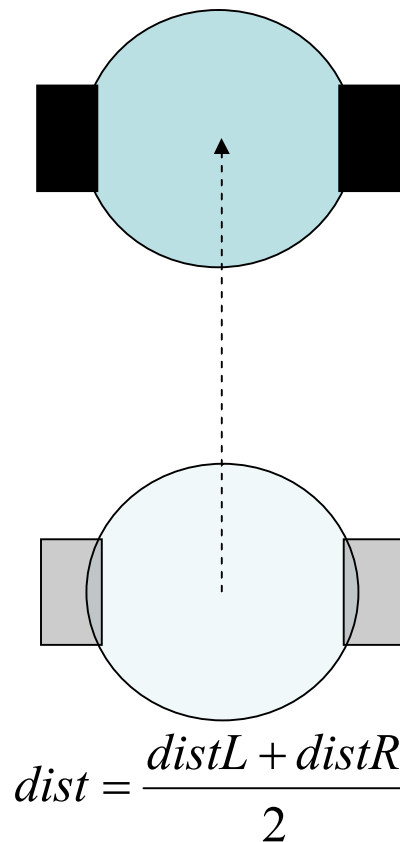

1. If a two wheeled mobile robot has moved its left wheel 20mm and right wheel 30mm, what distance has it travelled?
2. If the width of the robot is 100mm:
 - a) what would the final angle be?
 - b) Is this facing to the left or the right of the original position?
 - c) What is this angle in degrees?
 - d) Now draw the robot starting and final position on a

graph.

Level 1-Content



■ CREATE THE DIFFERENCE

Level 1-Content

- Path planning flood fill
- Place a '1' in the Goal position.
- Place a '255' in the black obstacle position.
- Place a '0' in every other square.

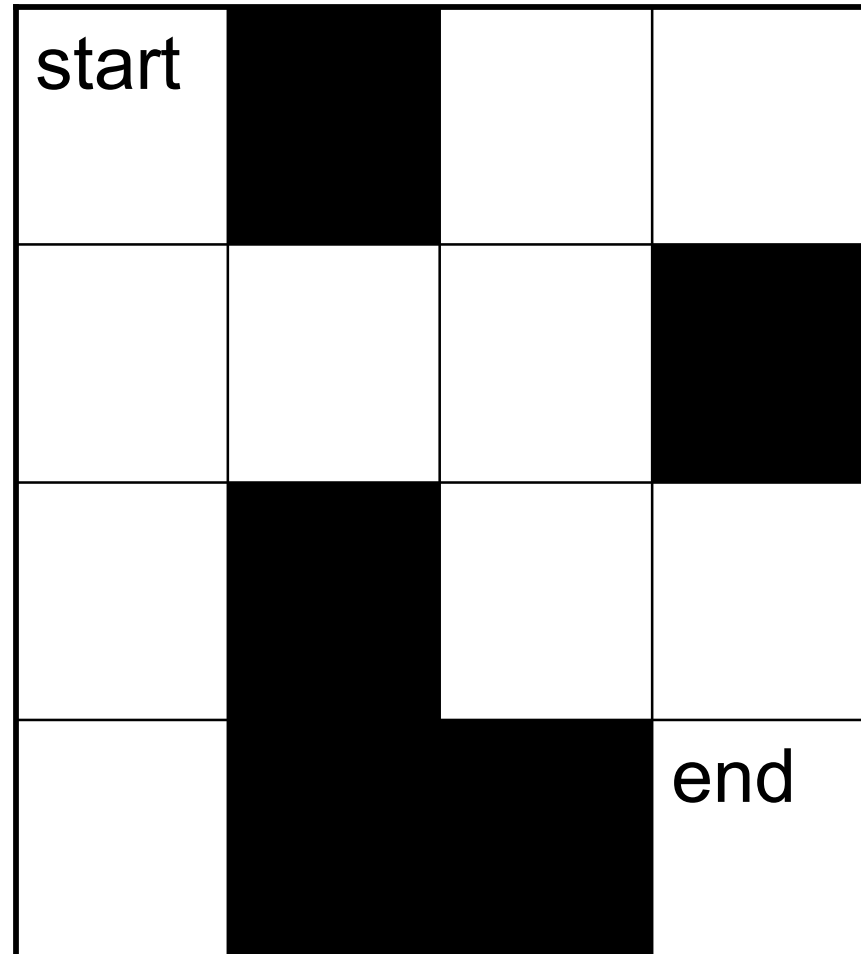

Path planning-1

- Use 4 point connectivity (up, down, left, right):
 - Starting from each square that has a '1', place a '2' into every adjacent square that is a 0.

| | | | |
|---|-----|-----|-----|
| 0 | 255 | 0 | 0 |
| 0 | 0 | 0 | 255 |
| 0 | 255 | 0 | 0 |
| 0 | 255 | 255 | 1 |

Path planning-2

- Use 4 point connectivity (up, down, left, right):
 - Starting from each square that has a '1', place a '2' into every adjacent square that is a 0.

| | | | |
|---|-----|-----|-----|
| 0 | 255 | 0 | 0 |
| 0 | 0 | 0 | 255 |
| 0 | 255 | 0 | 2 |
| 0 | 255 | 255 | 1 |

Path planning-3

- Starting from an array value of 2, place a '3' into every adjacent square that is a 0.

| | | | |
|---|-----|-----|-----|
| 0 | 255 | 0 | 0 |
| 0 | 0 | 0 | 255 |
| 0 | 255 | 3 | 2 |
| 0 | 255 | 255 | 1 |

Path planning-4

- Starting from an array value of 2, place a '3' into every adjacent square that is a 0.
- Repeat until no zeros remain.

| | | | |
|---|-----|-----|-----|
| 0 | 255 | 0 | 0 |
| 0 | 0 | 0 | 255 |
| 0 | 255 | 3 | 2 |
| 0 | 255 | 255 | 1 |

Path planning-5

- The path solution is to move to a lower value number

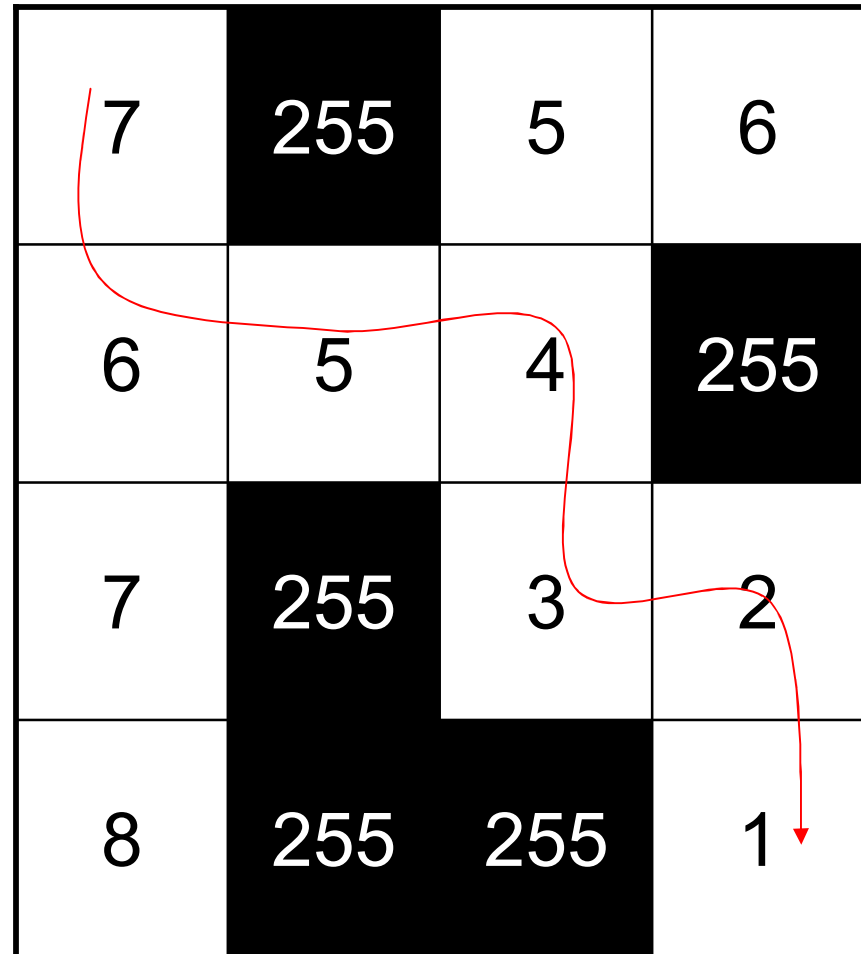

Level 2

- Cybernetics
 - Computers in control
 - Feedback control
- Microcontrollers
 - PIC (C18)
 - Electronics
 - Sensors
 - Motor drivers



Cybernetics-Labview

- Read a voltage
- Output a voltage

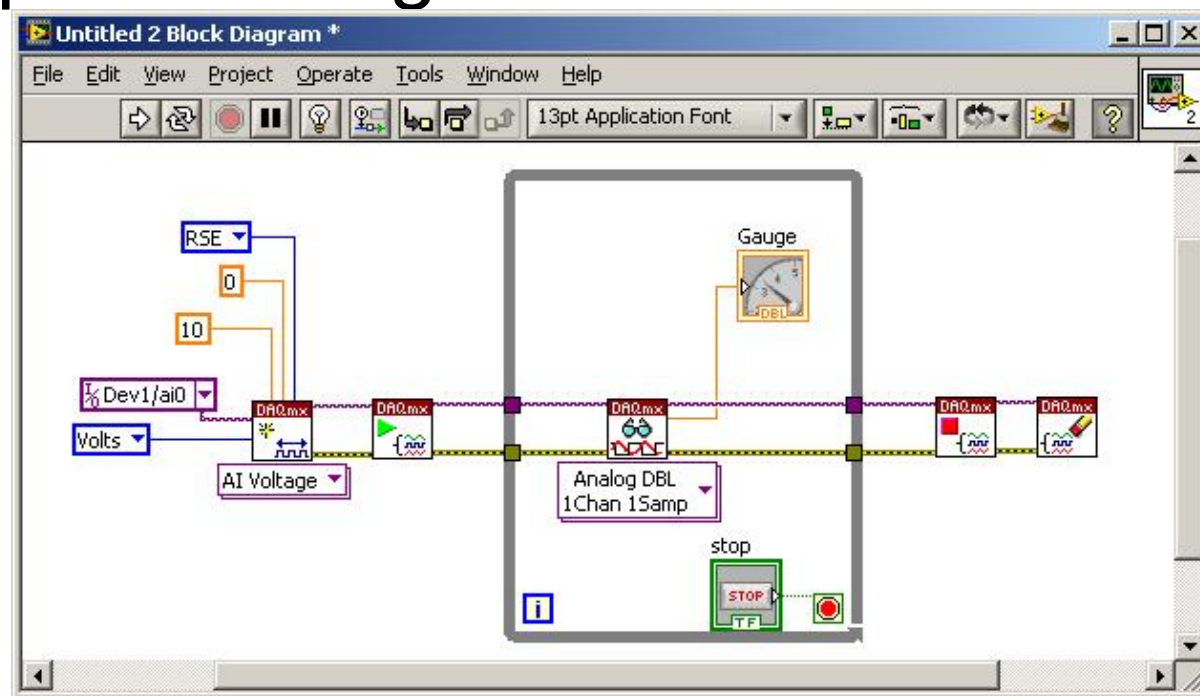

Feedback control

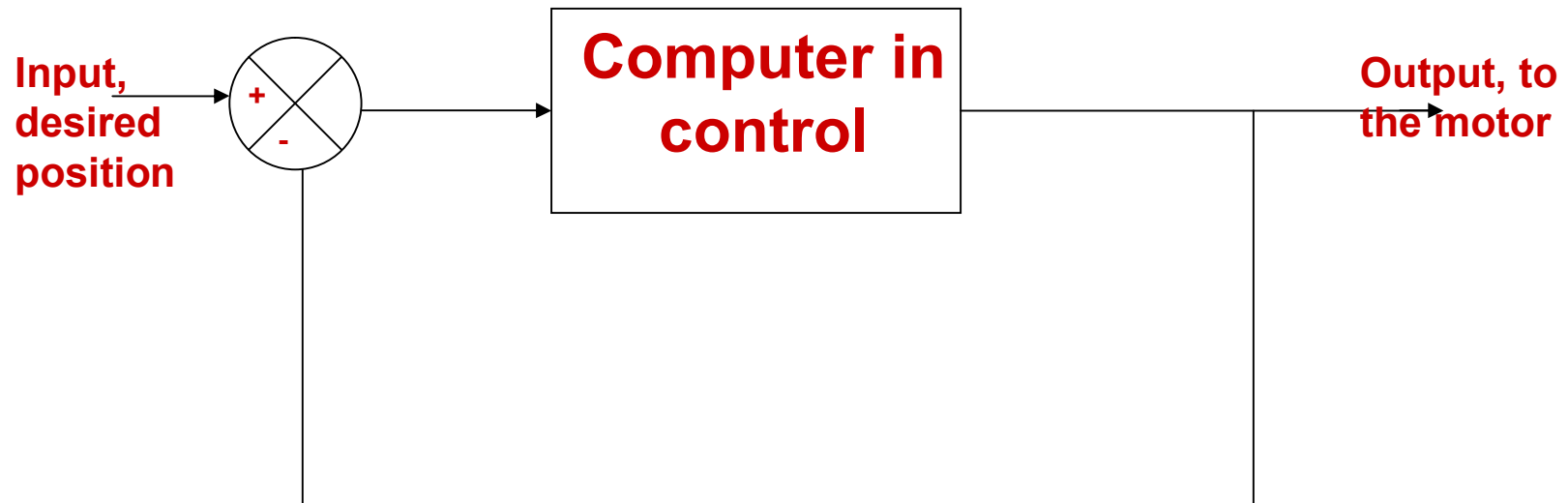

Helicopter

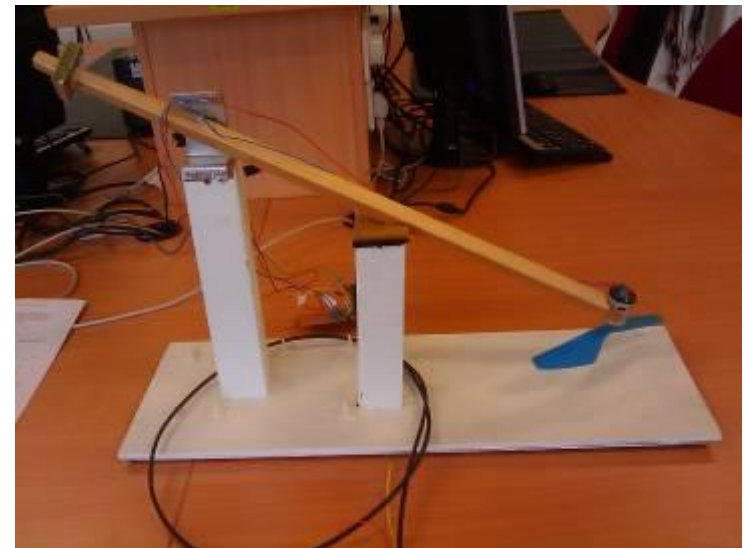
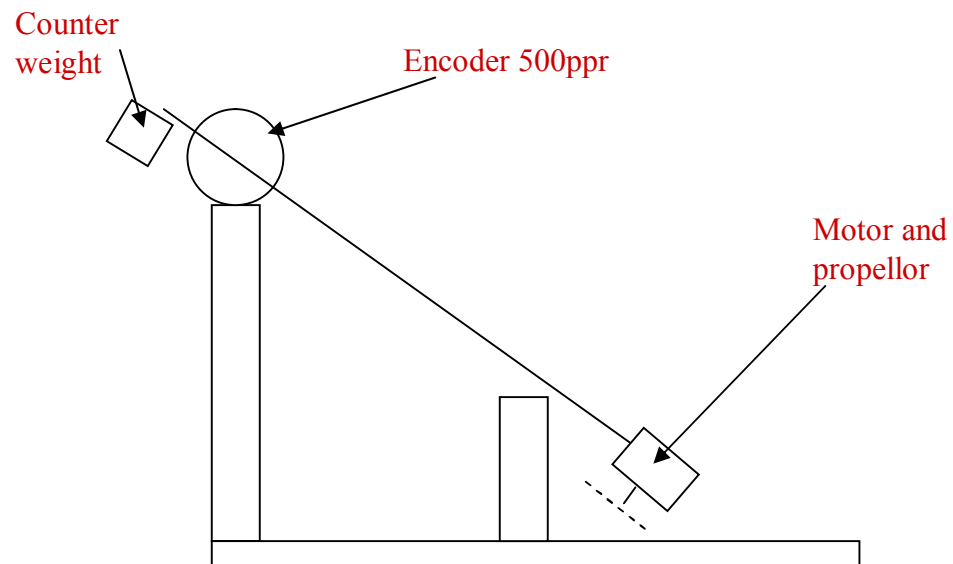

Level 3

- Robot manipulators
 - Kinematics
 - Motor control
 - C#
 - Ethics
 - Robot simulation
- Robots in factory
 - PLC
 - Vision
- Project

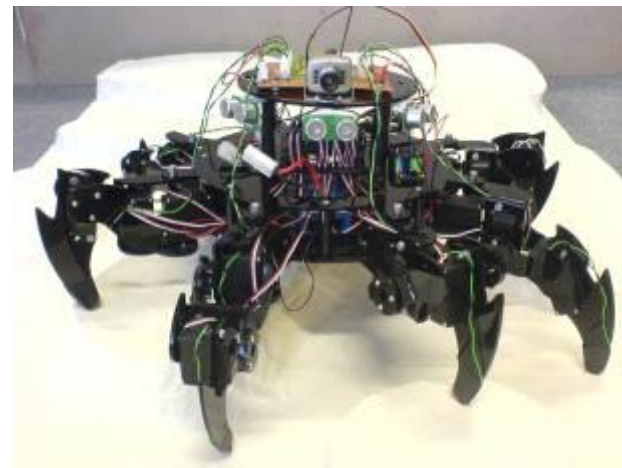
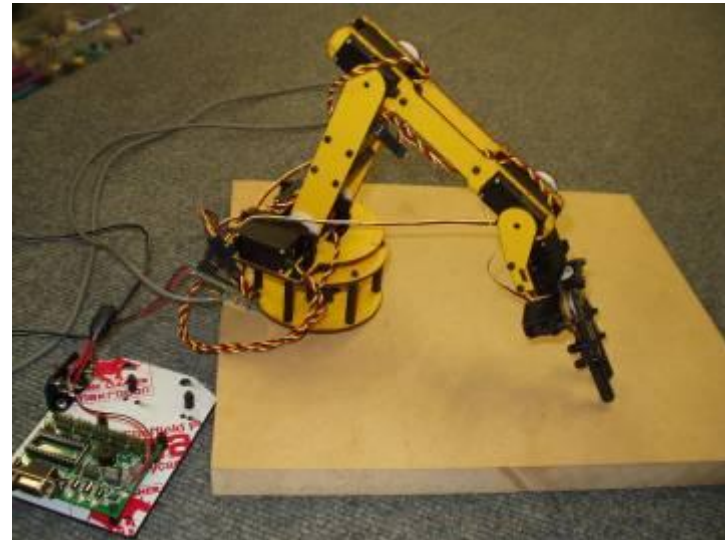

Level 3-Kinematics

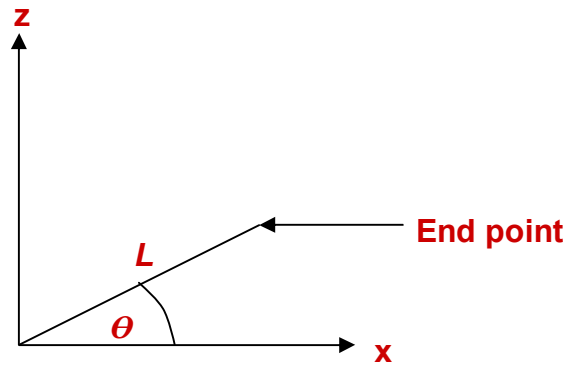

The forward kinematics of a simple link with link length L and moving through angle θ are:

$$x = L \cos \theta$$

$$z = L \sin \theta$$

Two link kinematics

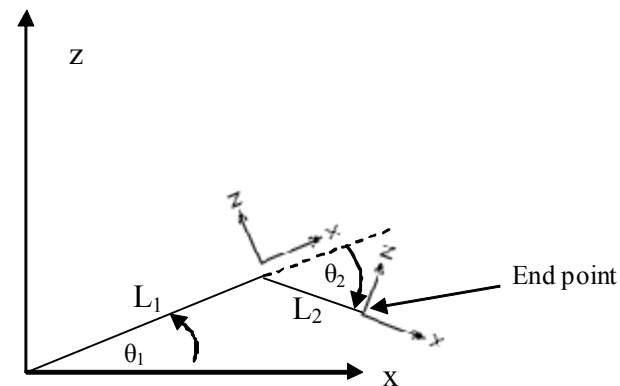

Figure 1 Rotation of a link

Referring to figure 2, the geometric solution for two links can be solved as:

$$x = L_1 \cos \theta_1 + L_2 \cos(\theta_1 + \theta_2)$$

$$y = L_1 \sin \theta_1 + L_2 \sin(\theta_1 + \theta_2)$$

Level 3-Robot Simulation

- ABB
- MATLAB
- Microsoft
- Schunk
- Roborealm

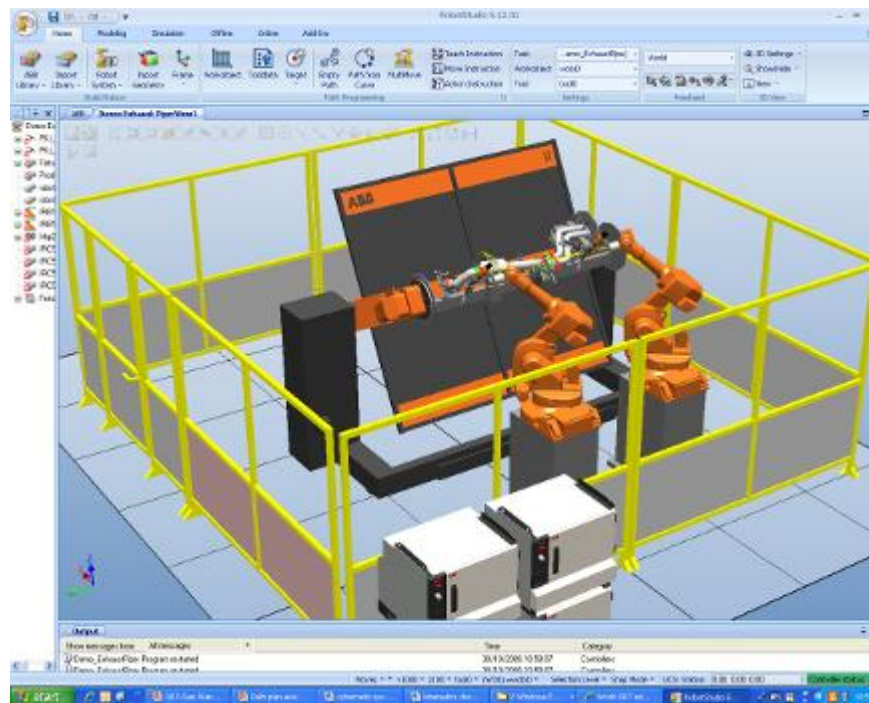

MSc



- A stand-alone condensed course covering robot theory and implementation:
 - Robot Control
 - Robot Kinematics
 - Robot Dynamics
 - Implementation
 - Control theory

MSc Projects

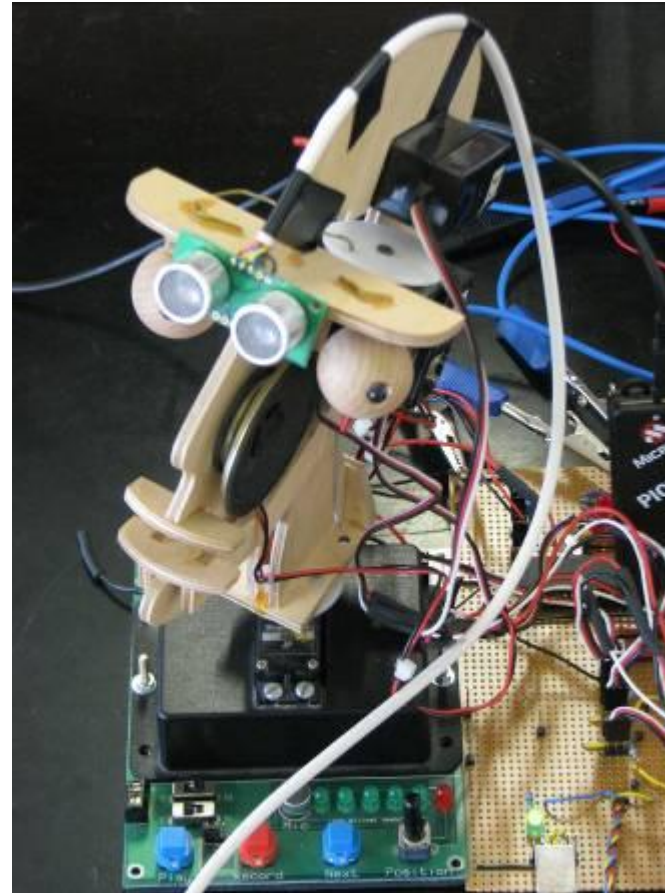

MSc Projects (2)

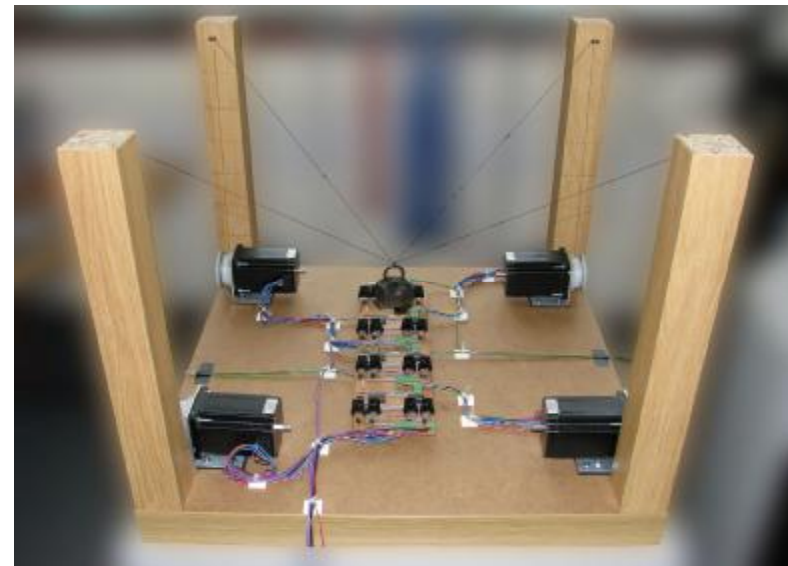
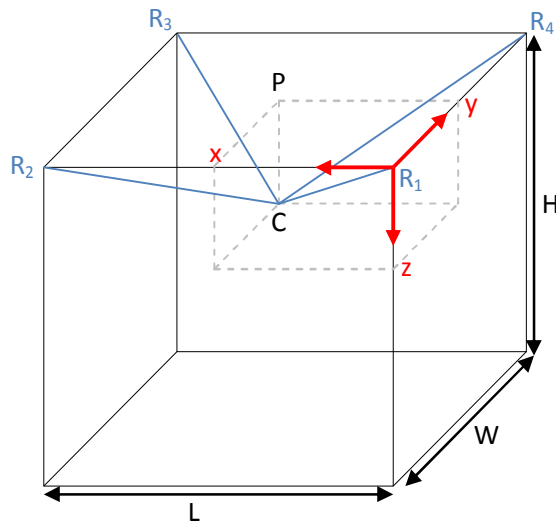

Research

- Human Adaptive Mechatronics
 - UK/Japan EPSRC funded (<http://www.epsrcham.org.uk>)
- JCB/Sellafield collaboration

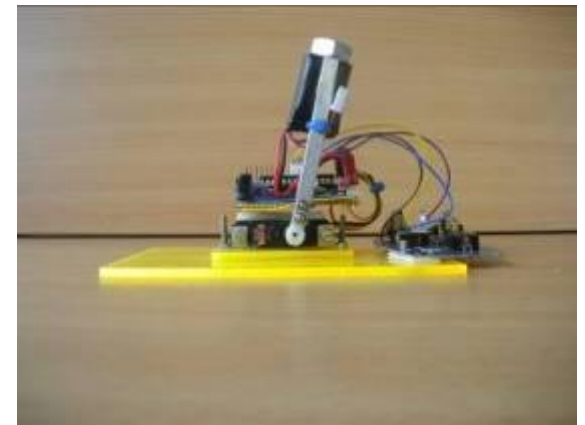

Public Engagement

- STEM ambassador
- IET Chairman
 - Sponsor Lego robots!
- Walking with Robots
- Café Sci
- Taster days (colleges, schools, AimHigher)
- TV (Gadget Show)



Robots in UK Competitions

RoboCup

- <http://www.robocup.org/>
<http://rcj.open.ac.uk/>
- <http://www.tech.plym.ac.uk/robofoot/>
- University of Plymouth



MoD Grand Challenge



- <http://www.challenge.mod.uk/>
- The challenge is to create a system with a high degree of autonomy that can detect, identify, monitor and report a comprehensive range of military threats in an urban environment. The Grand Challenge is open to the whole UK science and technology base, large and small companies, research laboratories and academic science faculties. It is also a challenge to UK financial institutions to invest in UK. The MOD is keen to see the best solutions developed quickly into equipment for the UK Armed Forces.



Micromouse UK

- <http://www.tic.ac.uk/micromouse/>

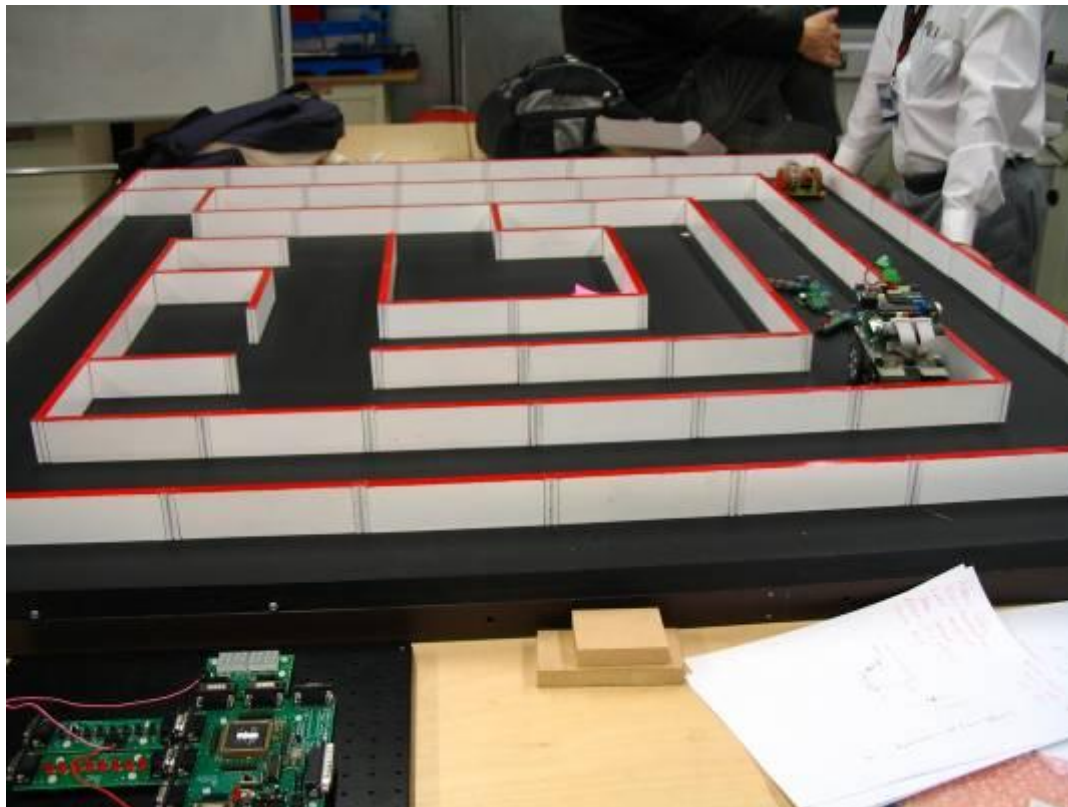

Walking with Robots

<http://www.walkingwithrobots.org>

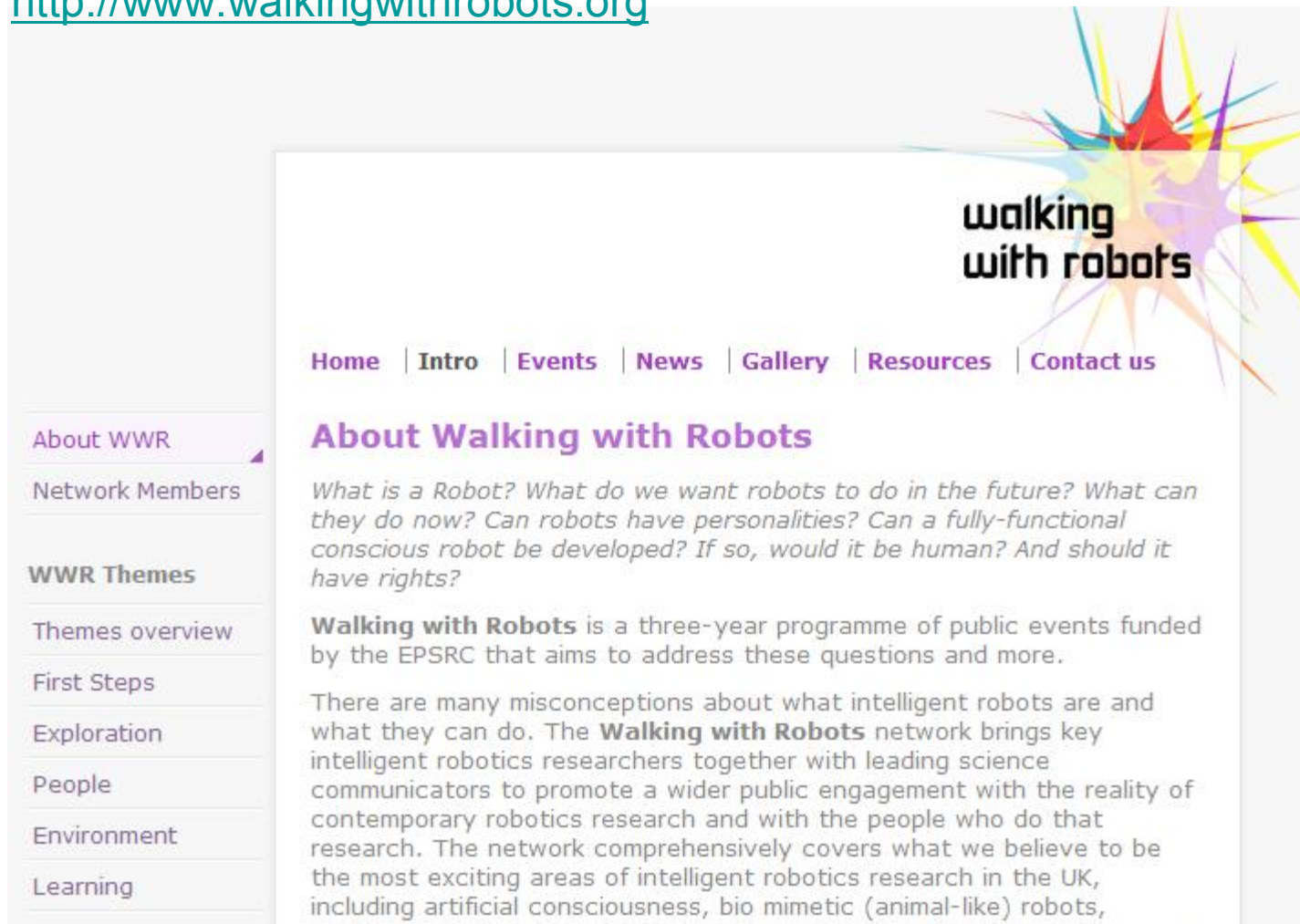

The screenshot shows the homepage of the Walking with Robots website. On the right side, there is a colorful starburst graphic with the text "walking with robots" overlaid. Below the graphic is a navigation menu with links: Home, Intro, Events, News, Gallery, Resources, and Contact us. On the left side, there is a sidebar menu with the following items: About WWR (highlighted), Network Members, WWR Themes, Themes overview, First Steps, Exploration, People, Environment, and Learning. The main content area features a section titled "About Walking with Robots" with a paragraph of text: "What is a Robot? What do we want robots to do in the future? What can they do now? Can robots have personalities? Can a fully-functional conscious robot be developed? If so, would it be human? And should it have rights?" Below this is another paragraph: "Walking with Robots is a three-year programme of public events funded by the EPSRC that aims to address these questions and more." The final paragraph states: "There are many misconceptions about what intelligent robots are and what they can do. The Walking with Robots network brings key intelligent robotics researchers together with leading science communicators to promote a wider public engagement with the reality of contemporary robotics research and with the people who do that research. The network comprehensively covers what we believe to be the most exciting areas of intelligent robotics research in the UK, including artificial consciousness, bio mimetic (animal-like) robots,

Eurobot



• <http://www.eurobot.org/>

The header banner of the Eurobot website. On the left is the Eurobot logo, which consists of a blue oval with the word 'eurobot' in yellow and a yellow robot figure. Below the logo are small flags of France, the UK, Germany, and Spain. On the right, there is a grid of flags representing various countries, with the text 'Direct access to national contests' site' above them. At the bottom of the banner is a navigation menu with links: Home, Presentation, Eurobot 2007, Eurobot 2008, Eurobot 2009, Junior, Forum, Press, Contact, Archives.

WELCOME TO EUROBOT!

An amazing event gathering fun, high technology, friendship, creativity, education and passion!

Created in 1998, Eurobot is a international amateur robotics contest open to teams of young people, organised either in student projects or in independent clubs. Eurobot takes place in Europe but also welcomes countries from other continents. In 2006, 26 countries, represented by 350 teams, have been involved in this science and technology contest, through its national qualifications and the international final that will take place in Catalane (Italy).



USEFUL LINKS

[Rules](#)
[National Cups](#)
[Partners](#)

OLDER NEWS

Eurobot 2007 LIVE !

23/05/2007

2009 call open

17/02/2007

FAQ 2 on line

31/01/2007

Register to Eurobot 2007

05/12/2006

FAQ 1 on line

23/11/2006

--->

WITH SUPPORT OF ...



EUROBOT 2007 **CREATE THE DIFFERENCE**

UK Skills

• <http://www.ukskills.org.uk/>

Skills Challenge
Promoting excellence through skills competitions

[Online registration](#) | [Competition Organisers' website](#)

[Home](#) | [About us](#) | [Competitions](#) | [Awards](#) | [News and Publications](#) | [Useful Links](#) | [Contact](#)

You are in: [Home](#) > [Competitions](#) > [Manufacturing](#)

- Construction & Building
- Creative Arts
- Engineering
 - Aircraft Maintenance
 - Autobody Repair
 - Automobile Technology
 - Car Painting
 - CRUD
 - CNC Milling and Turning
 - Industrial Control
 - Industrial Electronics
 - Manufacturing Team Challenge
 - Mechatronics
 - Mobile Robotics
 - Welding
- Healthcare/Personal Services
- Hospitality
- IT and Media
- Open Challenges

Mobile Robotics



Competition in brief

Who can enter?
The mobile robotics competition is designed for two individual competitors to work as a team. The competitors may work for the same company, attend the same training establishment or be two individuals from different centres.

The competition is for robotics technicians under 25 years of age. It is designed to attract entrants from all levels of expertise and related robotics qualifications.

Competition entry level?

- Advanced and higher levels

Search

enter search text →

Enter this competition

- Skills Challenge Competition Rules 2007
- Team entry
- Live competition
- Eligible for progressing to WorldSkills Competition

Contact & more information

ukilling@ukskills.org.uk

Find your competition



First Lego League

• <http://firsthandtechnology.org.uk/>

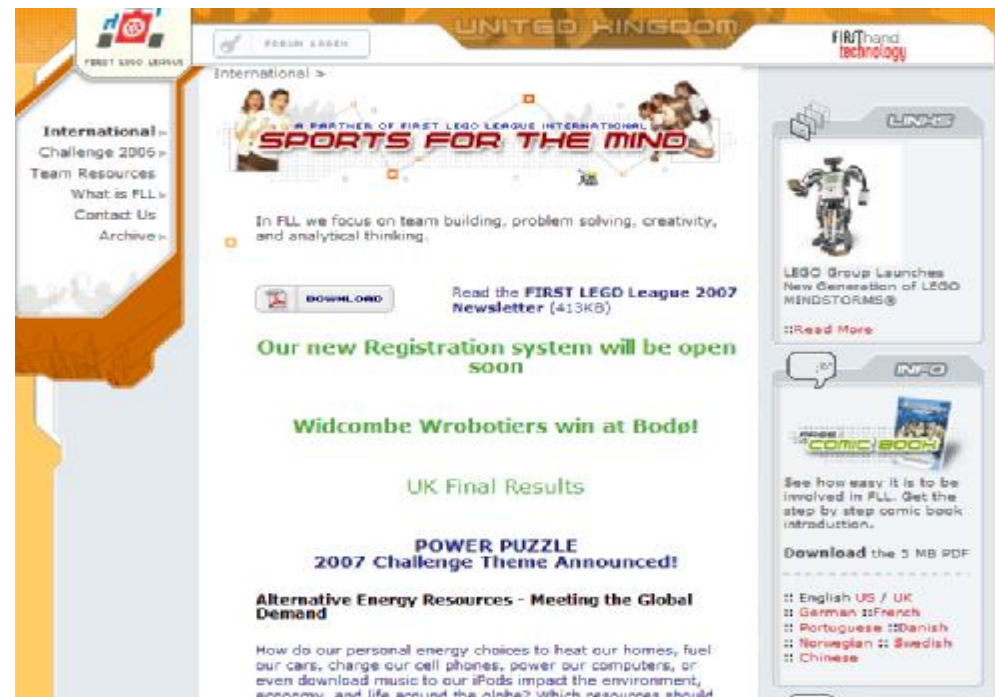

The screenshot shows the website for the First Lego League in the United Kingdom. The page features a navigation menu on the left with links for 'International - Challenge 2006', 'Team Resources', 'What is FLL', 'Contact Us', and 'Archive'. The main content area includes a 'FORUM & BLOG' section, a 'SPORTS FOR THE MIND' banner, and several news items: 'In FLL we focus on team building, problem solving, creativity, and analytical thinking.', 'Read the FIRST LEGO League 2007 Newsletter (413KB)', 'Our new Registration system will be open soon', 'Widcombe Wrobotiers win at Bodø!', 'UK Final Results', 'POWER PUZZLE 2007 Challenge Theme Announced!', and 'Alternative Energy Resources - Meeting the Global Demand'. A 'DOWNLOAD' button is visible next to the newsletter link. The right sidebar contains 'LINKS' and 'INFO' sections, including a link to 'LEGO Group Launches New Generation of LEGO MINDSTORMS®' and a 'COMIC BOOK' download link.

Summary

- There are plenty of jobs involving robotics
- Advanced robot concepts can be taught using Lego
- Robotics isn't just robots-it includes feedback computer control, sensors, microcontrollers etc
- A majority of the software is available for free
- Schools are crying out for robotics tutorials
- There are loads of competitions for all ages

The Zen of Work and Play



A master in the art of living makes little distinction between his work and his play, his labour and his leisure, his mind and his body, his education and his recreation, his love and his religion.

He hardly knows which is which.

He simply pursues his vision of excellence in whatever he does, leaving others to decide whether he is working or playing.

To him, he is always doing both.

Websites discussed



- www.fcet.staffs.ac.uk/sow1
- S.o.wane@staffs.ac.uk
- www.staffs.ac.uk
- <http://bricxcc.sourceforge.net/>
- <http://www.ni.com/>
- <http://www.bytronic.net/>
- <http://www.fbk.com/>
- <http://www.festo.co.uk>
 - http://www.festo.com/cms/en-gb_gb/5022.htm
- <http://www.abb.co.uk/>
 - <http://www.abb.co.uk/product/us/9AAC111580.aspx?country=GB> The software page
- http://petercorke.com/Robotics_Toolbox.html Robotics Toolbox for MATLAB
- <http://msdn.microsoft.com/en-us/robotics/default.aspx> Microsoft Robotics Studio
- www.schunk.com Schunk Grippers + Software
- <http://www.microchip.com/> PIC microcontrollers + C software
- <http://www.roborealm.com/> Free robot vision software

Weblinks-2



- <http://www.epsrcham.org.uk>
 - <http://www.stemnet.org.uk/>
 - <http://www.cafescientifique.org/>
 - <http://www.juniorcafesci.org.uk/>
 - <http://www.theiet.org/>
 - <http://www.britishcouncil.org/science-briefing-sheet-24-robotics-july03.doc>
 - www.walkingwithrobots.org
 - <http://robots.ning.com/>
 - <http://www.ukrobotgroup.com/>
 - <http://www.robocup.org/>
 - <http://rcj.open.ac.uk/>
 - <http://www.tech.plym.ac.uk/robofoot/>
 - <http://www.challenge.mod.uk/>
 - <http://www.robofesta-europe.org/britain/>
 - <http://www.tic.ac.uk/micromouse/>
 - <http://www.eurobot.org/>
 - <http://www.ukskills.org.uk/>
 - <http://firsthandtechnology.org.uk/>
 - www.teachers.tv
- HAM Japan/UK research group
Science ambassador
Café Scientifique
Junior Café Scientifique
Inst Engineering and Technology
British Council
Walking with robots
Social networking site
Forum for UK robotics
Robo Cup
Junior Robo Cup
Robo Cup winners
MoD Grand Challenge
Robo Festa
Micromouse
Eurobot
UK Skills
First Lego League
Teachers TV